

M140TGT

14" Intel® Core™ i5-1135G7 Industrial Rugged Tablet Integrated Smart Card Reader



KEY FEATURES

- 11th Gen. Intel® Processor Family – Tiger Lake Processor industrial rugged tablet
- 14-inch tablet, 1920 x 1080 wide viewing angle LED Panel
- Optical bonding and Antiglare technology for sunlight readability
- IP65 water and dust proof with MIL-STD-810H rugged housing
- Hot-swappable battery for wholedaywork
- Integrated Smart Card Reader



SPECIFICATIONS

Display			
Bonding	Optical Bonding for Sunlight Viewability	Resolution	1920x1080
Size	14.0 inches	Contrast Ratio	800:1
Panel Brightness	700.0 nits	View Angles	85,85,85,85
Type	Projected Capacitive Multi Touch		
System Specification			
Processor	Intel Core i5-1135G7 2.4GHz (up to 4.2GHz)	Memory	8GB DDR4 SDRAM 16GB DDR4 SDRAM (Optional) 32GB DDR4 SDRAM (Optional)
Storage	256GB SSD Additional storage available with micro SDXC card slot 512GB SSD (Optional) 1TB SSD (Optional) 2TB SSD (Optional)	Security	Trusted Platform Module (TPM) 2.0 Kensington Lock
Operating System	Windows 10 IoT Enterprise LTSC (64 bit) Windows 11 IoT Enterprise LTSC (64 bit) (Optional)	WLAN	Support
BT	Support	WWAN	4G LTE (Optional) 5G (Optional)
GNSS	GPS, GLONASS (Optional)	RFID	HF RFID reader 13.56 MHz (Optional)
Sensors	Light sensor/ G-sensor / Gyro	Smart Card Reader	Built-in Smart Card Reader, Comply with ISO7816-1.2.3 T=1 and T=Ø protocol
Camera			
Front Camera	2MP Front Camera	Rear Camera	8MP Rear Camera with auto-focus and LED light
Mechanical			
Dimension	341.91 x 224.67 x 25.4 mm	Weight	1.75 kg
Cooling System	Fan Design		
IO Ports			
USB Port	2 x USB 3.0 (Type A), 1 x USB 3.0 (Type-C support Power Delivery 20V In)	SD Card Slot	1 x Micro SDXC slot
SIM Card Slot	1 x Nano SIM card slot	Video	1 x Micro HDMI (Optional)
Audio	1 x Audio combo 3.5mm audio combo jack Dual Digital Mic With Noise Cancellation Dual Speaker	LAN	1 x RJ45-10/100/1000 GigaLAN port
Indicator	4x LED Indicator for Power, Battery, HDD, RF status	Docking Connector	1 x 19-pin docking connector

Environment			
Operating Humidity	10% to 90% RH, non-condensing	Operating Temperature	-20°C to 60°C
Storage Temperature	-30°C to 70°C (-22°F to 158°F)	Shock	MIL-STD-810H Method 516.8 Procedure I
Vibration	MIL-STD-810H Method 514.8 Procedure I	IP rating	IP65
Drop	MIL-STD-810H Method 516.8, 4 ft		
Certification			
Certification	CE, FCC		
Security Function			
SOTI MobiControl	SOTI MobiControl Compliance	Kensington Lock	Kensington Lock Support
Control			
Button	1 x Power, 3 x function keys		
Power			
Battery	Internal Battery: 10.8V typ. 2400 mAh Li-Ion Battery Hot-swappable 11.4V, typ. 3500 mAh Li-Ion Re-chargeable Battery (3S1P)	Power Rating	19V DC
Adapter	100-240V, 50-60Hz / 19V DC		
Accessory			
Accessory	Adapter and Power Cord Standard Battery Capacitive Stylus	Optional Accessory	Kickstand (Optional) Vehicle Charger (Optional) Battery Charger (Optional) Desk Dock (Optional) Carry Bag (Optional)

DIMENSIONS UNIT:MM

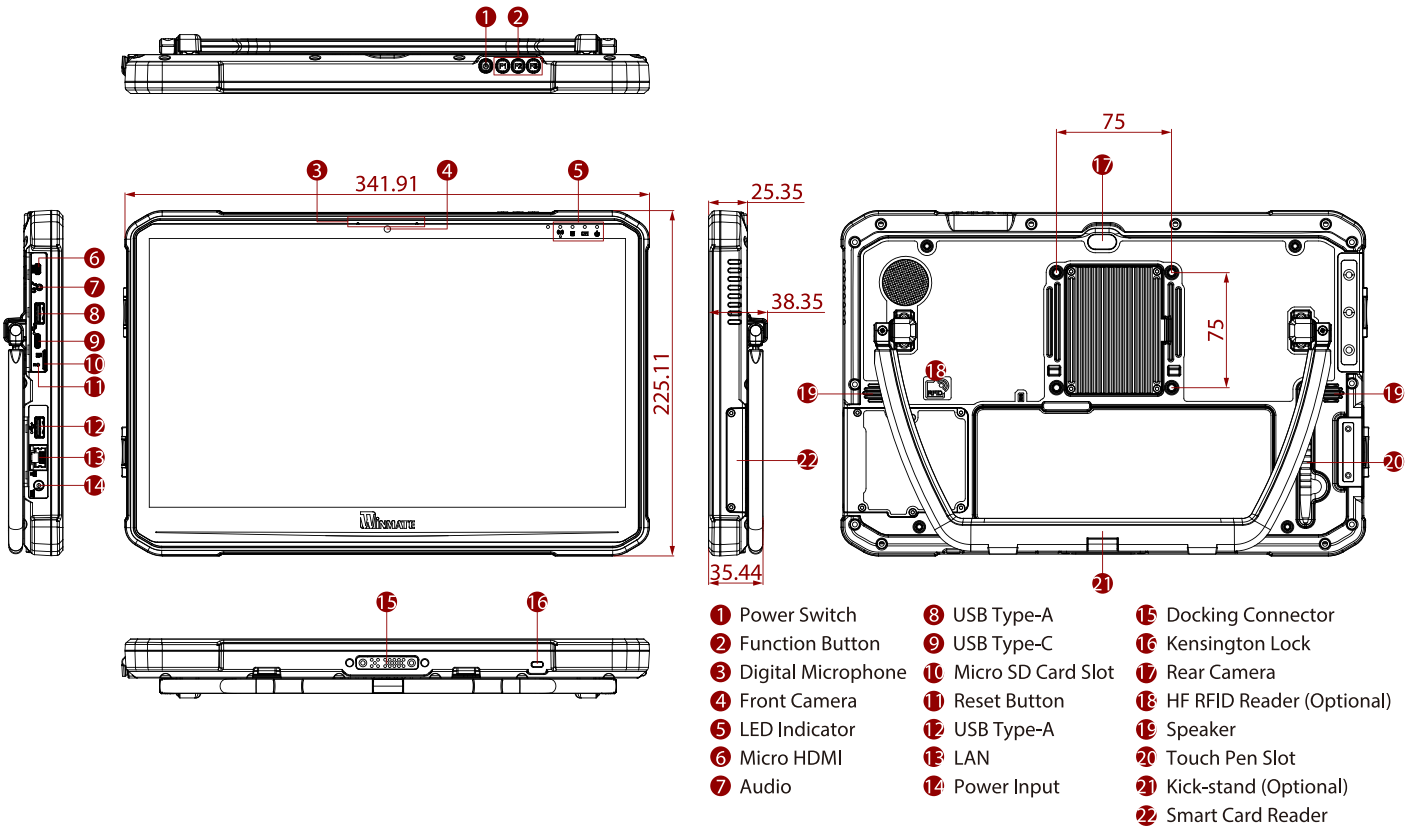

- 1 Power Switch
- 2 Function Button
- 3 Digital Microphone
- 4 Front Camera
- 5 LED Indicator
- 6 Micro HDMI
- 7 Audio
- 8 USB Type-A
- 9 USB Type-C
- 10 Micro SD Card Slot
- 11 Reset Button
- 12 USB Type-A
- 13 LAN
- 14 Power Input
- 15 Docking Connector
- 16 Kensington Lock
- 17 Rear Camera
- 18 HF RFID Reader (Optional)
- 19 Speaker
- 20 Touch Pen Slot
- 21 Kick-stand (Optional)
- 22 Smart Card Reader

NOTE

1. This is a simplified drawing and some components are not marked in detail.
2. Please contact our sales representative if you need further product information.
3. All specifications are subject to change without prior notice.
4. The product shown in this datasheet is a standard model. For diagrams that contain customized or optional I/O, please contact the Winmate Sales Team for more information.

