

R15L100-67C3-P(HB)

15" G-WIN IP67 Series P-CAP Display



KEY FEATURES

- High Quality 15" Panel, 1024 x 768 resolution, 1000 nits
- P-cap multi touch screen Optical Bonding with Panel to increase the clarity and transparency
- Optional True Flat 5 Wire Resistive Touch Optical Bonding with Panel
- Optional Anti-Reflective Protection Glass Optical Bonding with Panel
- Dust/ Water proof design with VESA mount Full IP67 Monitor
- Aluminum Die-Casting Housing with Anti-Corrosion Treatments
- Build in ambient Light sensor
- -10 to 55°C wide operating temperature
- Wide Range 9 to 36V DC Input with isolation. Optional for Ignition On/Off delay



SPECIFICATIONS

Display			
Resolution	1024x768	Size	15.0 inches
Contrast Ratio	2000:1	Panel Brightness	1000.0 nits
Display Color	16.2M Colors	View Angles	88,88,88,88
Active Area	304.1x228.1 mm	Touch / Glass	Projected Capacitive Multi Touch Screen Bonding With Panel True Flat Resistive Touch Screen Bonding With Panel (Optional) True Flat Protection Glass Bonding With Panel (Optional)
Mechanical			
Dimension	379.4 x 278.4 x 58 mm	Weight	3.8 kg
Mounting	VESA Mount	Enclosure	Aluminum Housing Pre finish: Surtec 650, Type II, Class 3 Coating: Polyester powder coating
Cooling System	Fanless design		
Environment			
Operating Humidity	10% to 90% RH, Non-Condensing	Operating Temperature	-10°C to 55°C -40°C to 70°C (with intelligent heater)
Storage Temperature	-30°C to 70°C	Shock	MIL-STD-810G Method 516.6 Procedure I
Vibration	MIL-STD-810G Method 514.6 Procedure I	IP rating	IP67
Certification			
Certification	CE, FCC		
IO Ports			
Power Input	1 x M12 waterproof connector for 9~36V DC	USB Port	1x M12 type connector for Touchscreen via USB signal
Serial Port	1 x M12 type connector for Touchscreen via RS232 signal (Optional) 1 x M12 type connector for RS232 Remote Control (Optional)	Video	1x M12 type connector for VGA input 1x Waterproof connector for HDMI input
Indicator	1 x LED Indicator for power		

1 x LED Indicator for lock/unlock status

Control	
Button	1 x "Power" key to power on the device. 1 x "+" key to increase screen brightness. 1 x "-" key to decrease screen brightness. 1 x "Menu" key can Automatically or manually adjusts brightness of the display screen 1 x Day / Night Mode button 1 x LED indicator brightness adjustment button 1 x Ambient Light sensor
Accessory	
Accessory	External open wire Power cable with waterproof connector External USB cable with waterproof connector for Touch External VGA cable with waterproof connector External HDMI cable with waterproof connector Waterproof caps VESA screws
Optional Accessory	100~240V AC to DC 50W Adapter with power cord (Optional) External RS232 cable with waterproof connector for Remote Control (Optional)
Ordering Information	
Option	R15L100-67C3-R(HB) for Resistive Touch (Optional) R15L100-67C3-G(HB) for Anti Reflective Protection Glass (Optional)

DIMENSIONS UNIT:MM

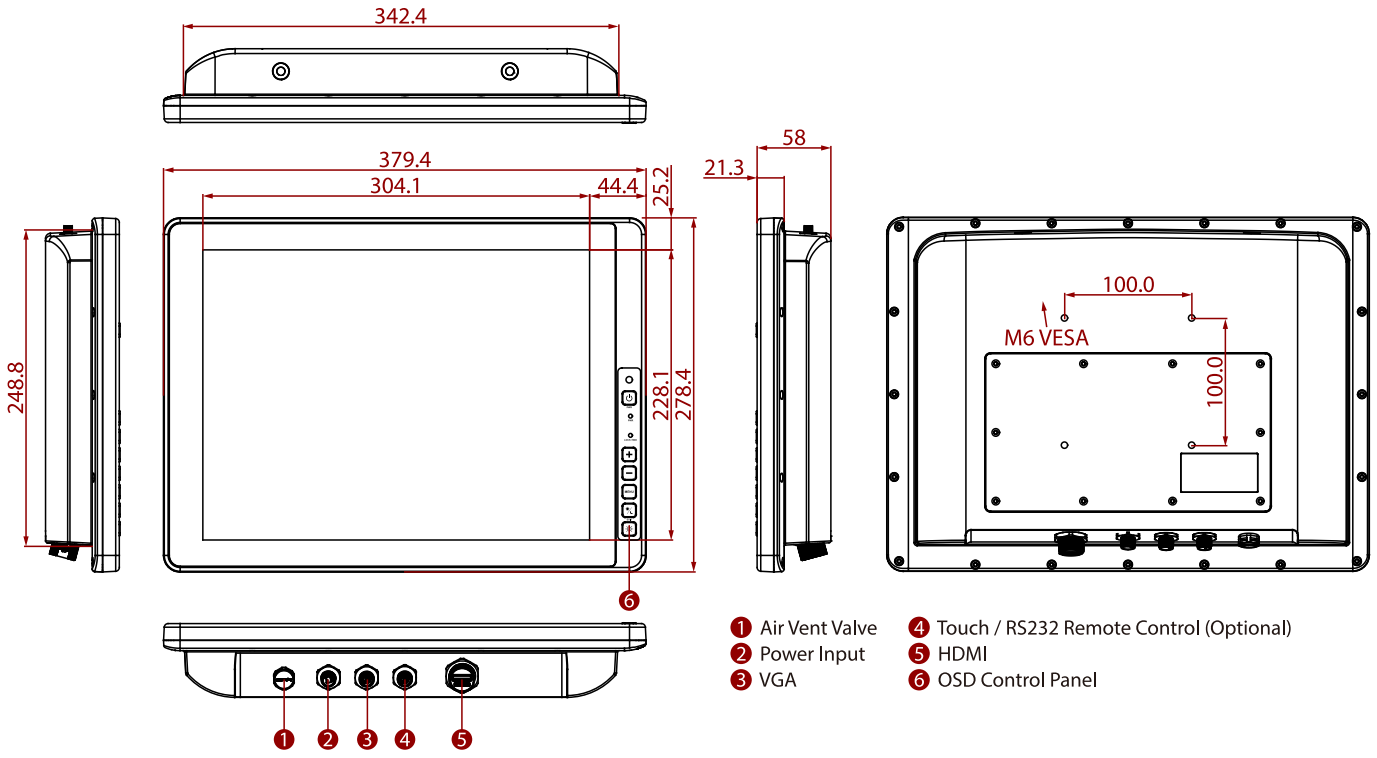

NOTE

1. This is a simplified drawing and some components are not marked in detail.
2. The product shown in this datasheet is a standard model. For diagrams that contain customized or optional I/O, please contact the Winmate Sales Team for more information.
3. All specifications are subject to change without prior notice.